

FireHalt™

Flexible Cavity Fire Barrier Systems

FITTING INSTRUCTIONS: *Please read carefully before commencing installation*

SEQUENCE OF WORK TO FIT FIREHALT GOLD CAVITY FIRE BARRIERS & FIREHALT SF FIRE BARRIERS

ILLUSTRATION OF A FITTED BARRIER

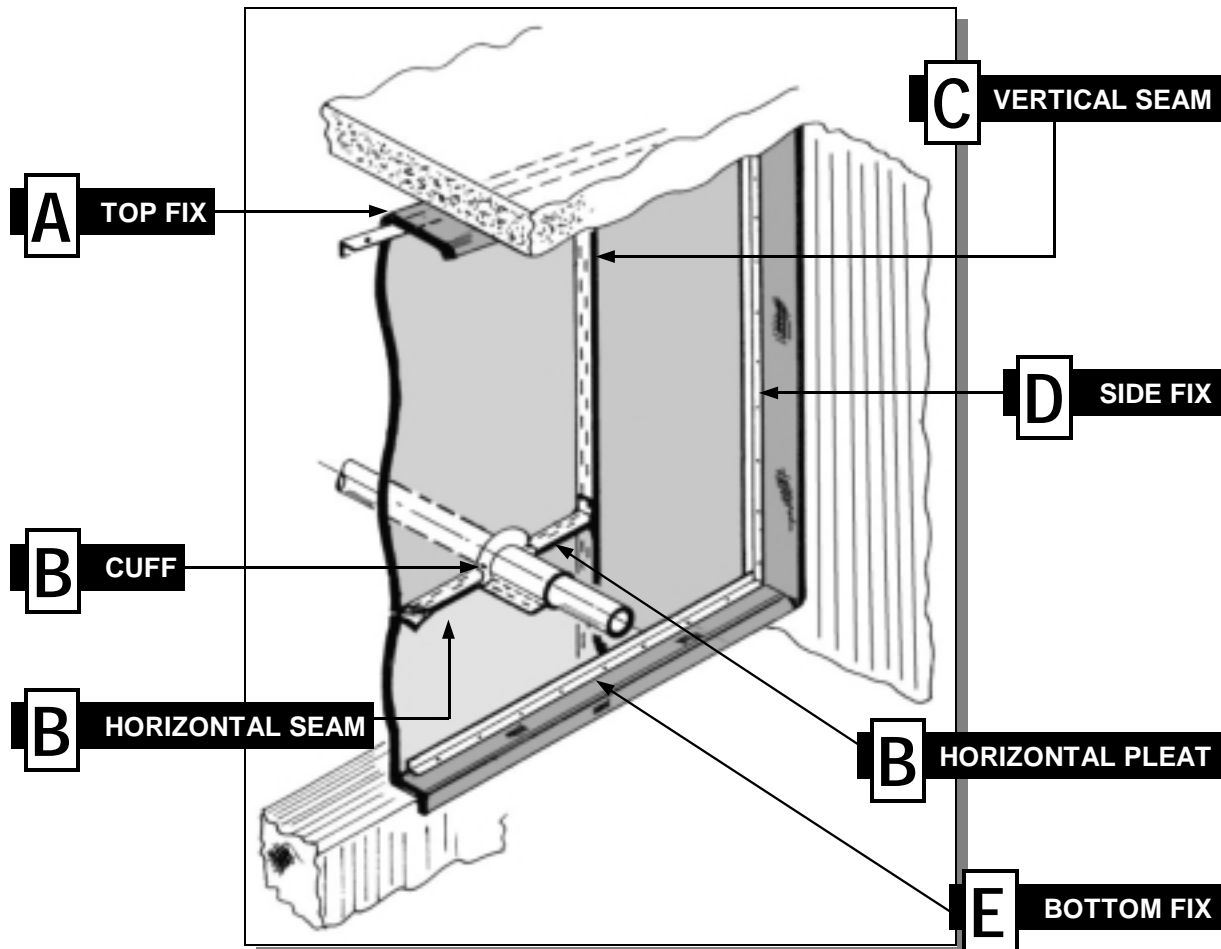

KEY NOTES AND TIPS TO REMEMBER

- 1 All galvanised angle fitting should be continuous by overlapping a minimum of 300mm.
- 2 Staples used should be a minimum 12mm, galvanised.
- 3 Allow a 100mm overlap for the side fixing on the first piece.
- 4 Loose fixing the top fix allows for the vertical seam to be made.

CUTTING THE BARRIER TO LENGTH

Before cutting the barrier to length allow:

- a 100mm overlap for the top fix.
- b 100mm overlap for the bottom fix.
- c 100mm for the penetrations.

(see relevant section)

Flexible Cavity Fire Barrier Systems

FITTING INSTRUCTIONS: *Please read carefully before commencing installation*

SEQUENCE OF WORK TO FIT FIREHALT GOLD CAVITY FIRE BARRIERS & FIREHALT SF FIRE BARRIERS

QUICK REFERENCE

- 1 AFTER CUTTING THE BARRIER TO THE REQUIRED LENGTH, 'LOOSE FIX' THE BARRIER TO THE TOP PERIMETER.
- 2 WORK THE BARRIER AROUND ANY SERVICE PENETRATIONS WITH HORIZONTAL AND PLEAT SEAMS.
- 3 FORM THE VERTICAL JOINT.
- 4 COMPLETE THE SIDE FIX.
- 5 FIT SUBSEQUENT LENGTHS OF BARRIER AS REQUIRED.
- 6 COMPLETE THE TOP FIX.
- 7 COMPLETE THE BOTTOM FIX.

* Cuffs can be fitted as work progresses or upon completion.

TOP FIX DETAIL

A

Outline

50mm galvanised stud is fixed to the soffit, the barrier is loose fixed to the stud. To complete the top fix a section of galvanised angle (25mm x 25mm x 0.5mm) is fixed to the stud, with self-drilling screws, trapping and securing the barrier with a 100mm overlap.

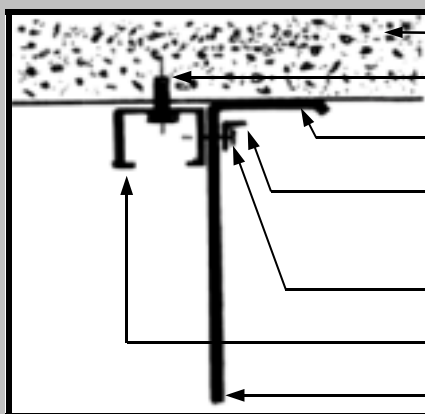

- 1 Soffit
- 2 Suitable fixings @ 250 centres
- 3 100mm material overlap
- 4 Galvanised angle - 25mm x 25mm x 0.5mm
- 5 Self drill & tap screws
- 6 Galvanised stud - 50mm section
- 7 Barrier

Flexible Cavity Fire Barrier Systems

FITTING INSTRUCTIONS: Please read carefully before commencing installation

SEQUENCE OF WORK TO FIT FIREHALT GOLD CAVITY FIRE BARRIERS & FIREHALT SF FIRE BARRIERS

SERVICE PENETRATIONS

B

Outline

Where a service or services penetrate the barrier a hole will be formed and require to be sealed.

The operation is simple and effective with the use of a “FireHalt Cuff”.

The first operation is to work the barrier around the penetration.

The second operation is to “cuff” the penetration.

Operation One:

CUTTING & REJOINING THE BARRIER

- 1 Working from the short edge of the barrier, cut the barrier, 50mm below the horizontal centre of the penetration, from the edge to the vertical centre of the penetration. (*drawing 1B*).
- 2 Feather cut a hole for the size of the penetration. (*drawing 2B*).
- 3 Feed the barrier over and around the penetration smoothing the feathered sections toward the face. Lift the barrier to form a 50mm deep pleat extending from the uncut edge to the penetration hole. Staple the pleat in position. Pull the edges of the cut side together and form a horizontal seam. Work the barrier tight against the penetration with staple fixings smoothing out the feathered sections toward the face. (*drawing 3B*).

A horizontal pleat seam is formed on the uncut side of the barrier (see seaming section).

A horizontal seam is formed on the cut side of the barrier (see seaming section).

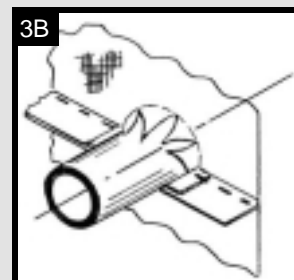
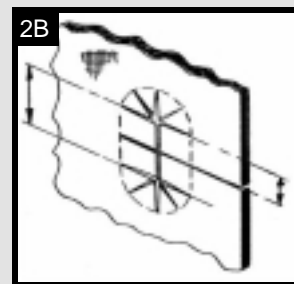
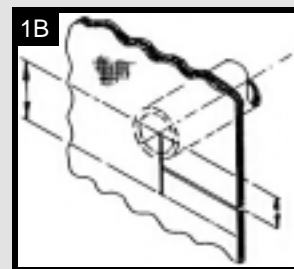

Flexible Cavity Fire Barrier Systems

FITTING INSTRUCTIONS: Please read carefully before commencing installation

SEQUENCE OF WORK TO FIT FIREHALT GOLD CAVITY FIRE BARRIERS & FIREHALT SF FIRE BARRIERS

SERVICE PENETRATIONS

B

Operation Two:

FITTING THE FIREHALT CUFF

- 1 The cuffs are a standard 1000mm and can be cut to size to suit the penetration circumference. When cutting the cuff to size ensure that a tab (120mm) is created on the cut edge of the flange. (**drawing 4B**).
- 2 To determine the length required, wrap the cuff around the penetration to create a tight fit, add a further 70mm for seaming and cut. (**circumference plus 70mm**).
- 3 Wrap the cuff around the penetration working it so that the edges are in line with the horizontal seam. Staple the barrel of the cuff at 50mm centres to create a tight fit, leaving 100mm unstapled at the barrier end. (**drawing 5B**).
- 4 Press the cuff flange against the barrier and fold the flange over the pleat seam. Secure with 12mm staples. (**drawing 6B**).
- 5 Tuck the feathered sections under the cuff barrel and staple the remainder of the barrel seam for a tight fit with 12mm staples
- 6 Lay the upper flange tab over the horizontal seam and secure with two 12mm staples. Pull the lower flange tab over the horizontal seam and secure with two 12mm staples (**drawing 7B**).

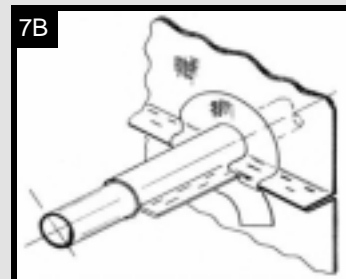
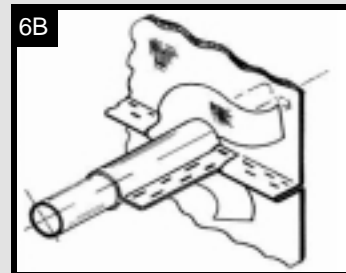
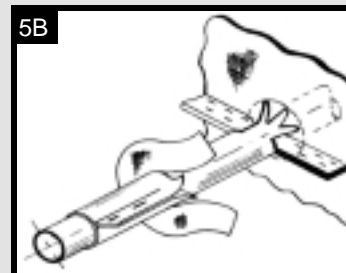
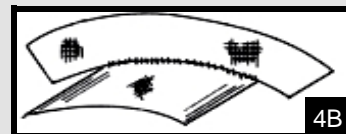

Flexible Cavity Fire Barrier Systems

FITTING INSTRUCTIONS: Please read carefully before commencing installation

SEQUENCE OF WORK TO FIT FIREHALT GOLD CAVITY FIRE BARRIERS & FIREHALT SF FIRE BARRIERS

B

HORIZONTAL JOINTS

Outline

Horizontal joints are formed to extend the length of the barrier in a way that maintains the barriers overall performance. The horizontal joint is also used, in conjunction with a pleat seam for penetrations. The seam is achieved by pulling adjacent barrier edges together and stapling them into position.

FIREHALT GOLD Double Safe Seam

- 1 Pull the two edges together to create a seam 50mm deep.
- 2 Staple the seam at 100mm centres with 12mm staples. This row of staples being 50mm in from the edge.
- 3 Insert a second row of 12mm staples 25mm in from the edge, midway between the first row of staples and the edge, at 100mm centres. The second row of staples being offset from the first row by 50mm.
- 4 The Double Safe Horizontal Seam is now complete.

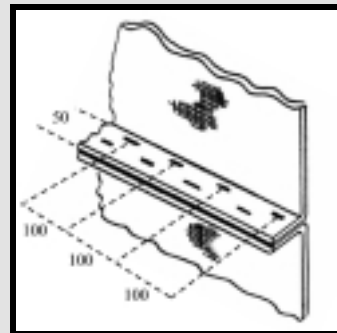

FIREHALT SF Turn Back Seam

- 1 Pull the two edges together to create a seam 50mm deep.
- 2 Staple the seam at 500mm centres with 12mm staples. This row of staples being 50mm in from the edge.
- 3 Turn back the barrier at 25mm and staple at 100mm centres with 12mm staples midway into the seam (12.5mm).
- 4 The Turn Back Horizontal Seam is now complete.

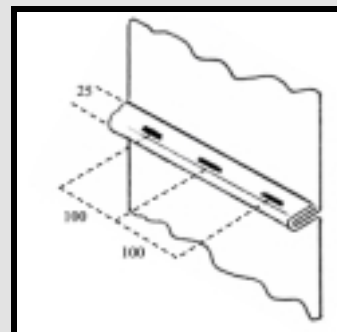
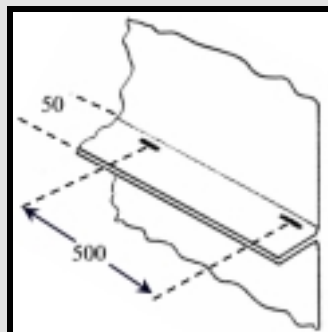

Flexible Cavity Fire Barrier Systems

FITTING INSTRUCTIONS: Please read carefully before commencing installation

SEQUENCE OF WORK TO FIT FIREHALT GOLD CAVITY FIRE BARRIERS & FIREHALT SF FIRE BARRIERS

B

HORIZONTAL PLEATS

Outline

Pleat seams are formed to keep the barrier length level on either side of a penetration. The short side, having been cut, will require a 50mm Horizontal Seam as detailed above. This will take 100mm out of the barrier length. To keep the barrier level a similar length needs to be taken from the other side. This is achieved by forming a 50mm pleat. This also takes 100mm out of the length of the barrier.

FIREHALT GOLD Pleat Seam

- 1 Pull up the barrier and form a pleat 50mm in depth on the opposite side to the cut barrier. The crown of the pleat should be in line with the horizontal centre line of the penetration.
- 2 Staple the seam at 100mm centres with 12mm staples. This row being 50mm in from the crown of the pleat.
- 3 Insert a second row of 12mm staples 25mm in from the crown of the pleat, midway between the first row and the crown of the pleat, at 100mm centres. The second row of staples being offset by 50mm.
- 4 The Pleat Seam is now complete, which will balance the length of the barrier.

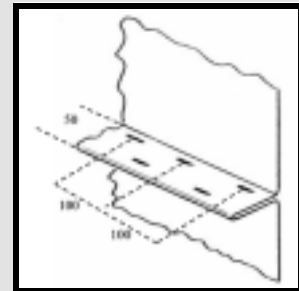

FIREHALT SF Pleat Seam

- 1 Pull up the barrier and form a pleat 50mm in depth on the opposite side to the cut barrier. The crown of the pleat should be in line with the horizontal centre line of the penetration.
- 2 Staple the seam at 500mm centres with 12mm staples. This row of staples being 50mm in from the crown of the pleat.
- 3 Turn back the barrier at 25mm and staple at 100mm centres with 12mm staples midway into the seam (12.5mm).
- 4 The Pleat Seam is now formed which will balance the length of the barrier after a penetration.

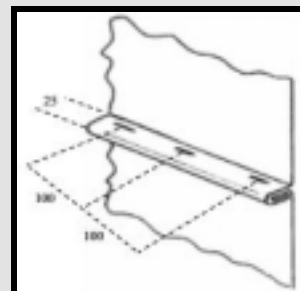
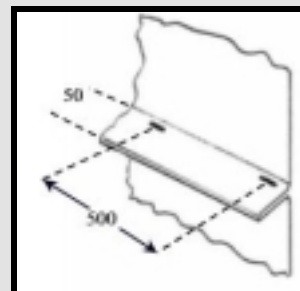

Flexible Cavity Fire Barrier Systems

FITTING INSTRUCTIONS: Please read carefully before commencing installation

SEQUENCE OF WORK TO FIT FIREHALT GOLD CAVITY FIRE BARRIERS & FIREHALT SF FIRE BARRIERS

VERTICAL JOINTS

C

Outline

Vertical joints are formed to extend the width of the barrier in a way that maintains the barriers overall performance. This is achieved by pulling adjacent barrier edges together and stapling them in position.

FIREHALT GOLD Double Safe Seam

- 1 Pull the two edges together to create a seam 50mm deep.
- 2 Staple the seam at 100mm centres with 12mm staples. This row being 50mm in from the edge.
- 3 Insert a second row of staples 25mm in from the edge, midway between the first row of staples and the edge, at 100mm centres. The second row of staples being offset from the first row by 50mm.
- 4 The Double Safe Vertical Seam is now complete.

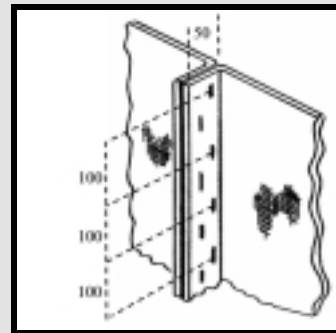

FIREHALT SF Turn Back Seam

- 1 Pull the two edges together to create a seam 50mm deep.
- 2 Staple the seam at 500mm centres with 12mm staples. This row of staples being 50mm in from the edge.
- 3 Turn back the barrier 25mm and staple at 100mm centres with 12mm staples midway into the seam (12.5mm).
- 4 The Turn Back Vertical Seam is now complete.

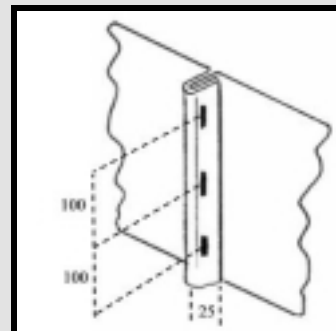
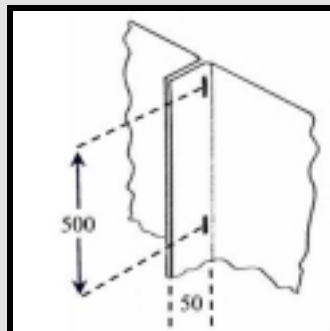

Flexible Cavity Fire Barrier Systems

FITTING INSTRUCTIONS: Please read carefully before commencing installation

SEQUENCE OF WORK TO FIT FIREHALT GOLD CAVITY FIRE BARRIERS & FIREHALT SF FIRE BARRIERS

SIDE FIX

D

Outline

The side fix secures the outer edge of the barrier to the main or secondary structure.

SIDE FIX FIREHALT GOLD & FIREHALT SF

- 1 Leaving a 100mm overlap, trap the outer edge of the barrier between the main and secondary structure and a section of galvanised angle (25mm x 25mm x 0.5mm) with suitable fixings, at 250mm centres.
- 2 The galvanised angle should be continuous. If joined the overlap should be a minimum of 300mm ensuring a fix is made through the join area.

Side fixing detail

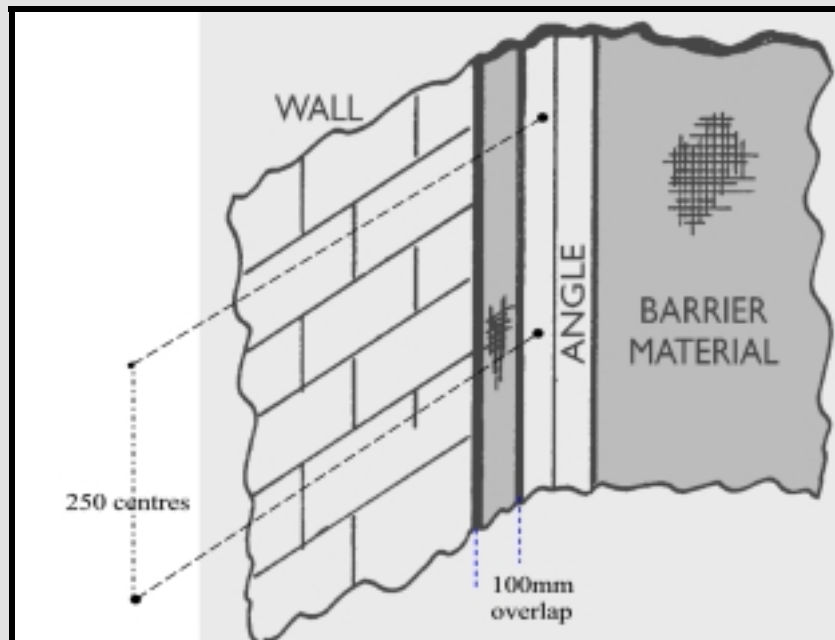

Flexible Cavity Fire Barrier Systems

FITTING INSTRUCTIONS: Please read carefully before commencing installation

SEQUENCE OF WORK TO FIT FIREHALT GOLD CAVITY FIRE BARRIERS & FIREHALT SF FIRE BARRIERS

BOTTOM FIX

E

Outline

The bottom fix secures the lower edge of the barrier to the main or secondary structure.

BOTTOM FIX FIREHALT GOLD & FIREHALT SF

Standard fixing:

Drawing 1E

- 1 Creating a 100mm overlap, trap the lower edge of the barrier between the structure and a section of galvanised angle (25mm x 25mm x 0.5mm) with suitable fixings, at 250mm centres.
- 2 The galvanised angle should be continuous. If joined the overlap should be a minimum of 300mm ensuring a fix is made through the joint.

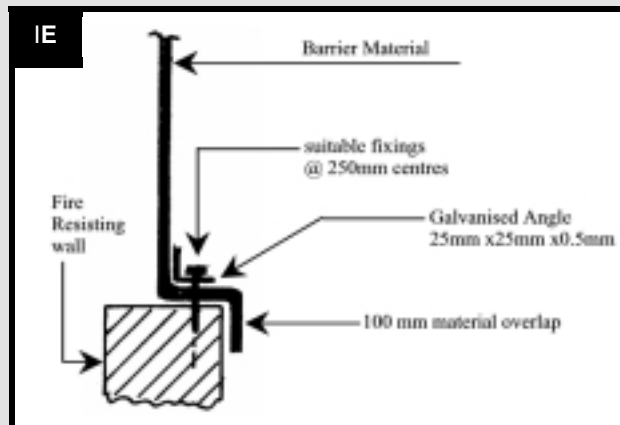

Fixing to a suspended ceiling:

Drawing 2E

- 1 Lay the bottom edge of the barrier adjacent to the "T".
- 2 Creating a 100mm overlap, fix the barrier to the bulb of the "T" with wide headed, self-drilling screws at 200mm centres.

